

PROTECTING FAMILY AND LIVESTOCK FROM **NUCLEAR FALLOUT**

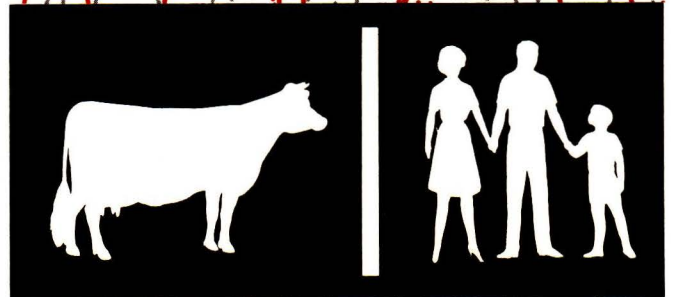
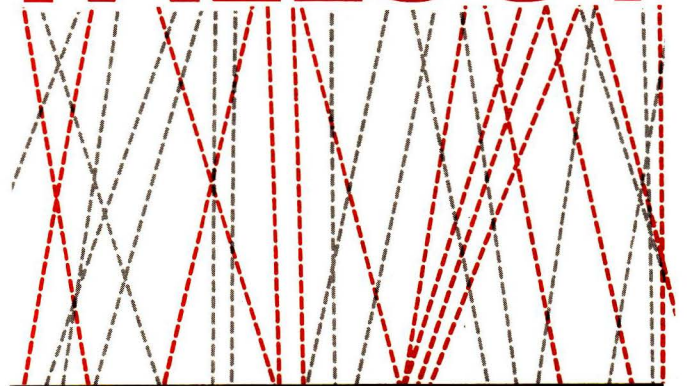

COOPERATIVE EXTENSION SERVICE
UNIVERSITY OF HAWAII
CIRCULAR 416

PROTECTING FAMILY AND LIVESTOCK FROM NUCLEAR FALLOUT

The prospect of nuclear war is horrible to contemplate. Because we trust that governments, ours and others, are striving to avert nuclear war—and because we do not like to think about a world devastated by nuclear bombs—many of us have made no plan to protect ourselves and our families against this awesome hazard.

The fact remains that nuclear war could happen. And if it did happen, whether by accident or design, there is a chance of survival for a large portion of the population if proper protective measures had been taken. Such protective measures deserve careful study and advance planning.

It is impossible to give definite and complete answers to every situation that could develop. The number and size of weapons, whether air- or ground-burst, how far you are from the blast, the direction and velocity of the wind, the terrain in your immediate area, and many other factors would affect the amount of protection you might need.

This booklet contains information that can help you prepare protection against nuclear fallout. The same facilities and supplies that you provide for this emergency can also be used for other emergencies such as tornadoes.

CONTENTS

	Pages
Radiation—facts, sources, and protection	1, 2
Providing Protective Shelters—procedure	3
Animal Shelter Requirements	4
Emergency Electrical Power	5
Human Shelter Requirements	6, 7, 8, 9
Shielding Requirements	10, 11
Constructing Shelters—Details and Examples	12 - 19
Complete plans for fallout shelters	20

If you wish further information, see your County Cooperative Extension Agent. He usually has information about the types of emergencies you might face, how to prepare for them, and how to resume normal operation.

In addition to making plans to protect your family and livestock, you should become familiar with your community civil defense plans. City and county officials can tell you about local organizations and the plans which have been prepared.

The planning of protection begins with a knowledge of radiation, how it is spread, and what it can do. This knowledge will provide judgment, and can help in deciding how to reduce the dangers of radiation. You will need to evaluate the protection you now have and consider steps for additional protection. In many instances, small changes can greatly improve the survival chances for your family and animals.

FACTS ABOUT RADIATION

Radiation is one kind of energy. It is caused by changes within atoms. Material that contains some of these changing atoms is called radioactive.

Radiation can kill or injure the living cells in human and animal body tissues. Humans and animals can be exposed to low-level radiation for a long time without apparent serious injury. Some cells may be damaged beyond repair, but cells which are only slightly damaged are able to repair themselves if given sufficient time.

However, intense radiation exposure causes sickness or death because the body is unable to repair the cell damage fast enough.

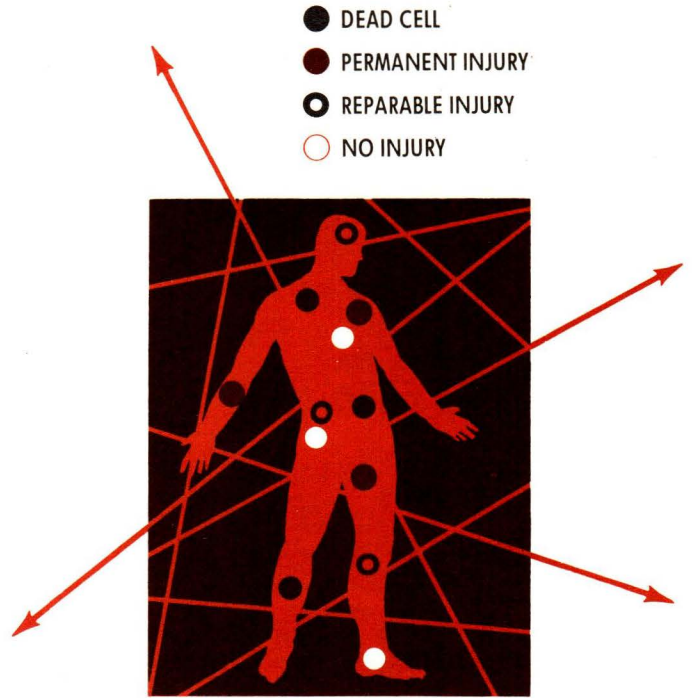

RADIATION

Radiation doses are measured in roentgens. As the radiation dose increases, the possibility of sickness and death increases as shown in the table below.

Estimated Medical Effects of Radiation Doses / PERCENT OF PEOPLE SICK

Total dose (roentgens)	Time During Which Total Dose Is Received				
	1 Day or less	3 Days	1 Week	1 Month	3 Months
0 to 125	0 to 15%	0 to 2%	0%	0%	0%
150	25%	10%	2%	0%	0%
200	50%	25%	15%	2%	0%
300	100%	60%	40%	15%	0%
450	100% (15% die)	100% (5% die)	90%	50%	0-5%
650	100% (50% die)	100% (25% die)	100% (15% die)	80%	5-10%
	100% (95% die)	100% (90% die)	100% (40% die)	100% (10% die)	

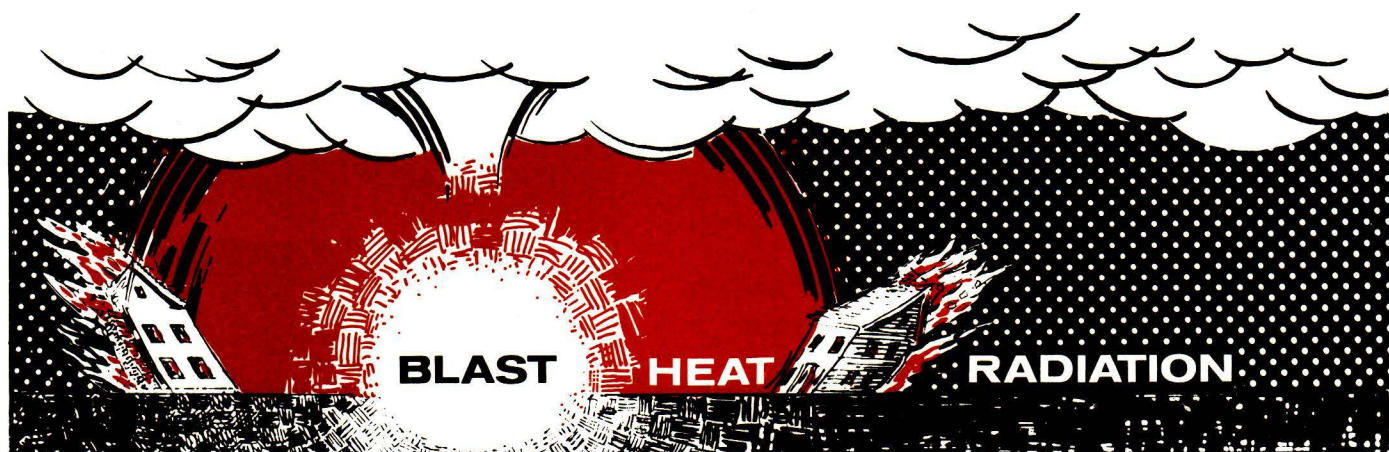

SOURCES OF RADIATION

Common Sources

The sun is a source of radiation, but its radiation is usually harmless because most is absorbed or filtered out by the earth's atmosphere. X rays are another source of radiation. X rays expose tissues to intense radiation and can be dangerous if not properly controlled. The beneficial uses of controlled X rays are well known.

Nuclear Explosion

A new and extremely hazardous source of radiation is the nuclear explosion.

A nuclear explosion causes destruction in three ways: blast, heat and radiation.

About half the destructive force of a nuclear explosion is "blast." This blast is a shock wave of compressed air and travels like the ripples from a stone dropped into a pond. It destroys or damages buildings within a few miles of the explosion by causing high pressures and strong winds. In the blast area, about 5 percent of the explosion energy is also released as initial radiation.

Thirty-five percent of the explosion energy is released as heat. This heat is intense enough to start fires and cause burns on unprotected persons.

The remaining 10 percent of the energy is called fallout radiation. This radiation is emitted from the debris that is formed during the blast. The debris is carried upward and mixes with radioactive materials of the bomb and forms a mushroom-shaped cloud.

Only very strong, reinforced underground shelters might protect against the blast and heat of a nuclear explosion, but fallout radiation can be stopped by shielding.

FALLOUT RADIATION

When the debris within the mushroom cloud falls back to earth, the larger particles will fall close to the explosion, while the smaller particles may be carried long distances by the wind. Fallout particles will not make other materials radioactive, but the radiation from these particles can kill cells, causing sickness or death.

Fallout is highly radioactive immediately after an explosion, but the radioactivity diminishes rapidly. After about 24 hours, the radiation level is about one-fiftieth of what it was 1 hour after the explosion. However, even this lower amount of radiation may be dangerous. Fallout is always dangerous as long as it emits radiation.

Just how far fallout may travel is difficult to predict, due to factors such as the size of the bomb or bombs, distance of the explosion off the ground, the kind of bomb, and the wind direction, speed and altitude. It is known that fallout can travel several hundred miles.

RADIATION PROTECTION

Some of the United States would be exposed to little or no radiation. But people and animals in fallout areas would have to be protected, or they will be exposed to radiation.

A simple fact makes it possible to protect people and livestock who are outside the blast and heat areas of a nuclear explosion. **ALL MATERIAL BETWEEN THE SOURCE OF RADIATION AND A PERSON OR ANIMAL WILL ABSORB SOME RADIATION ENERGY.** The heavier a material is per cubic foot, the more absorptive it is. As an example, two inches of concrete provides more absorption than two inches of wood because concrete is heavier per cubic foot.

Protection against nuclear radiation results from providing enough absorptive material for a shelter, and preparing to occupy that shelter for up to two weeks.

PROVIDING PROTECTIVE SHELTER

WHAT IS A PROTECTIVE SHELTER?

ALTERNATIVE 1

A minimum shelter is a small shielded area that will just keep you alive. This shelter requires only minimum space, a little water, and some way of moderating extreme inside temperatures.

ALTERNATIVE 2

A reasonable shelter is a larger shielded area equipped to provide reasonable living conditions but without all the conveniences. It will have reasonable space, food and water, and some way of moderating inside temperatures. It would also have other items such as a radio for receiving Civil Defense announcements, recreational supplies, etc. It might have emergency power so some appliances may be used.

Livestock shelters will have sufficient shielding, and enough feed, water, space and environmental control to prevent almost all permanent damage to the productive capacity of a selected group of animals.

ALTERNATIVE 3

All of the space in which you and your animals live can be shielded and equipped to be a shelter. This alternative requires extensive shielding and emergency power to operate all appliances and equipment. Livestock shelters would then be equipped to maintain the normal production of all animals.

WHICH ALTERNATIVE?

This book deals primarily with the requirements and details necessary for Alternative 2. The minimums needed to fulfill the first alternative are listed, but are not emphasized or recommended by the engineers who wrote this book.

REQUIREMENTS FOR ALTERNATIVE 2

1. The shelter should contain, or have easily accessible, enough food or feed, and water for up to two weeks.
2. The shelter should contain a reasonable amount of space for each occupant. The space needed for equipment, beds, food, and other items should also be considered. Recommended space requirements are listed on pages 4 and 8.
3. The shelter should have emergency power to operate fans and other needed equipment. This is especially important for livestock shelters.
4. The shelter must be shielded by enough material to reduce the radiation dose to tolerable levels. Most houses and farm service buildings do not have adequate shielding, and must have more added before they could be used as shelters. See page 10 for acceptable levels.

RECOMMENDED PROCEDURE

ANALYZE EXISTING BUILDINGS

The first step to providing an adequate shelter is to analyze existing buildings to see if they meet some, if not all, of the requirements listed above.

Buildings that will be replaced in the near future, or those that will be phased out of your operation, need not be analyzed.

The analysis of typical buildings shown on page 12 was made using the information given on pages 4 through 11. The few comments about how each building meets the requirements are guides that you may find useful. However, your buildings may have very different features, so study and use the information on pages 4 through 11 when making your analysis.

The radiation level for each building shown on page 12 is an indication of the radiation protection which that building is likely to provide. This level is a percentage of the 100 percent radiation exposure of that building. Radiation protection is also measured by PF, which means protection factor. A percentage of 2 1/2 is equivalent to a PF of 40; a PF of 25 is equivalent to 4 percent.

SELECT POSSIBLE SHELTERS

After the analysis of existing buildings is complete, select proposed shelters for your family and livestock. These proposed shelters may be one or several of the existing buildings, or they may be new buildings that you plan to have in the immediate future.

If you select existing buildings, pick those that most closely meet the requirements of food, water, emergency power, and space. It is usually easier to add more shielding than it is to provide these requirements.

EQUIP AND CONSTRUCT THE SHELTERS

Equip, or plan to equip, the selected buildings until they meet the first three requirements.

The shelters described on page 13 are the same buildings that were analyzed on page 12. The descriptions and additions show one way of improving each typical building. The amount of shielding required for each shelter was determined from the information on page 10. Note the difference in the radiation percentage.

A shelter in a new building should be equipped and constructed to meet all the requirements. Several shelters that can easily be placed in new buildings are shown on pages 16 and 17. Other plans can be obtained from the sources listed on page 20.

ANIMAL SHELTER REQUIREMENTS

Providing adequate shelters for all animals may be impractical or almost impossible. The time and effort needed to feed and water the animals during an emergency may be limited. A farmer might be exposed to hazardous levels of radiation if he spent more than about one hour each day caring for his animals. During this one hour, only limited care could be given to the animals, especially if emergency electrical power were not available.

Because of these limitations, a farmer will have to select a small number of animals to protect and maintain. Agricultural engineers recommend the following: Provide for breeding stock so that all survive; provide for production animals so most survive; and provide for market animals so about half survive. Shelters should include shielding, uncontaminated feed and water, and ventilation.

Consider placing all non-selected animals in a building that would offer at least some protection from fallout.

SHIELDING — SEE PAGE 10.

WATER, FEED AND SPACE

Animals can go without water for about 48 hours; they can go without feed for about a week. The amount of feed and water listed in the tables should be readily available and protected against contamination from fallout. Feed stored where fallout particles could not actually get on it would be safe. Examples: hay under canvas, corn in cribs, and grain in elevators.

Water Requirements Per Animal

Animal	Ample Supply Gal./day	Limited Supply Gal./day
Cattle	17	7
Hogs	2 1/2	1 1/4
Poultry		
layers and broilers	1/16	1/20
turkeys	1/3	1/8
Sheep	1 1/2	1

Minimum Feed and Space Requirements of Animals

	Feed/Day	Space Sq. ft.
Cattle		
Cow	1lb. hay/cwt. body wt.	20
Calf	1lb. hay/cwt. body wt. + 1/4lb. 40% protein suppl.	12
Sheep		
Ewe	1lb. alfalfa hay/cwt. body wt.	10
Lamb, 60lb.	1lb. alfalfa hay/cwt. body wt.	4
Swine		
Lactating sow	5lbs. corn + 1/2lb. 35% prot. suppl.	32
Hog 100lbs.	3lbs. corn + 1/2lb. 35% prot. suppl.	4
200lbs.	4lbs. corn + 1/2lb. 35% prot. suppl.	6
Poultry		
Laying hen	1/4lb. mash	0.7
10lb. turkey	0.4lb. mash	1.5
25lb. turkey	0.7lb. mash	2.0

Equivalent feeds may be substituted. Hay should be at least 1/2 legume.

Animals off feed 48 hours or more should be limited to about half their normal amount for a day. Then increase each animal's ration by 1 pound per day until up to normal.

VENTILATION

In cold and mild weather, ventilation is needed to remove moisture produced by the animals and to remove some of the odors. Some ventilation is needed even in very cold weather.

The summer rates listed in the table are needed during hot weather. About half of the rate is adequate for 2 or 3 days if outdoor temperatures stay below 90° F.

Provide the required ventilation with fans or with open windows or panels. Shield these openings to at least the elevation of the animals' backs.

Ventilation Required in Animal Shelters

Animal	Cfm/Animal Winter	Cfm/Animal Summer
Cattle		
400lb. calf	30	80
800lb. dairy	70	200
1000lb.	100	225
1600lb.	130	300
Hen	1/2	6
Sheep		
Nursing ewe	10	30
60lb. lamb	7	20
Swine		
Sow and litter	50	100
100lb. hog	15	40
200lb. hog	25	75

During a nuclear emergency, you will probably be unable to care for all your animals. But during a power outage caused by high winds or other cause, you will need enough emergency power to maintain your operation. Thus you may want to provide stand-by power for the more probable emergency. If you plan in this way, you may have more than would be used during a nuclear emergency.

INSTALLATION SUGGESTIONS

List all motors, lights, fans and other equipment to be operated under emergency conditions. Consult your power supplier; he will help you select a generator, and will provide instructions for installation and use.

The engine or tractor to run the generator should be protected from weather and rodents, adequately vented for dissipation of heat and fumes, and maintained in good running condition. Fuel supply should be adequate for at least 2 weeks.

Locate the generator where it can be used in an emergency with minimum risk to the operator. It should be near the entrance box, or fuse panel, and preferably in an area shielded from radiation.

A transfer switch must be installed between the power supplier's meter and the entrance box, and should be within sight of the generator.

MAINTENANCE

Run the engine and generator for one hour each month to keep the engine's battery charged. Check the wiring and fuel supply.

EMERGENCY OPERATION

1. Disconnect all circuits.
2. Put transfer switch in "generator" position.
3. Check fuel supply.
4. Start engine or tractor.
5. Check voltage; when up to 230v. for 120/240v. service, add load.
6. Connect largest load first, then progressively smaller loads.

TO RETURN TO COMMERCIAL POWER

1. Disconnect all circuits, stop generator, put transfer switch in "normal power" position.
2. Reconnect circuits, largest load first.

EMERGENCY ELECTRICAL POWER

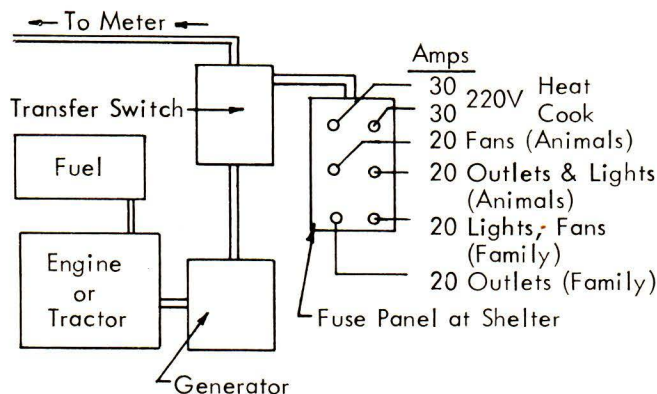

SAMPLE CIRCUITS

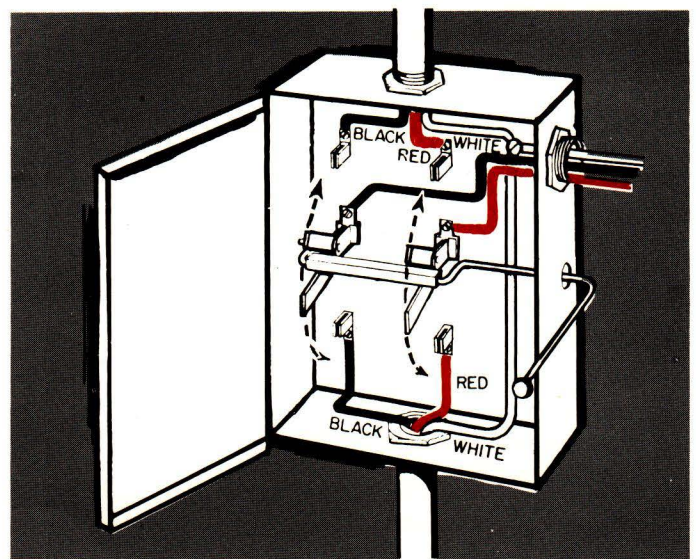

TYPICAL TRANSFER SWITCH (Double-pole, double-throw)



HUMAN SHELTER REQ

CHECK LIST

The list below is a guide for stocking your shelter with the necessary equipment and supplies. You can adapt this list to your own family situation. These items should be kept in the shelter or stored where they would be readily accessible during shelter occupancy.

WATER & FOOD

- Water (2-wk. supply, 7 gallons per person)
- Food (2-wk. supply)
- Eating utensils
- Plates, bowls, cups (preferably disposable)
- Openers for cans and bottles
- General-purpose knife
- Measuring cup
- Cook stove (canned heat or camp stove)
- Fuel and matches
- Cooking pans and utensils
- Baby foods
- Nursing bottles and nipples

SANITATION

- Covered can for garbage (20-gal.)
- Covered pail for toilet purposes
- Covered can for human wastes (10-gal.)
- Toilet tissue, paper towels, sanitary napkins, clean rags, ordinary and waterless soap, detergent.
- Grocery bags, plastic bags, and newspapers for soil bags
- Disinfectants and insecticides
- Waterproof gloves
- Disposable diapers

MEDICAL

- First aid kit and supplies
- First aid or medical self-help reference material
- Special medicines such as insulin or allergy pills
- Special equipment for invalids

READING & RECREATIONAL

- Bible or other religious materials
- Civil Defense and medical publications
- Books or magazines
- Games (adult and child)
- Pencils, paper, etc.

GENERAL

- Battery-operated radio and spare batteries
- Flashlight, electric lantern or other emergency lighting
- Dosimeter
- Home firefighting equipment
- Screwdriver, pliers and other tools
- Shovel, axe, saw, crowbar, or other rescue tools
- Clothing
- Bedding
- Clock and calendar
- Rope

UIREMENTS

WATER

Provide each family member with one-half gallon (1 qt. minimum) of uncontaminated water per day, or 7 gal./person for 2 weeks. It is desirable to have another half gallon per person per day for hygienic purposes.

Boil the water 30 minutes before placing it in sterile containers. Check the water in one container after a month to see if any undesirable taste or smell has developed. If an undesirable taste or smell is present, start again. After the first month's test proves good, check the water annually.

In an emergency, you could obtain additional water if you had enough warning. Bathtubs and sinks could be filled. The water in toilet flush tanks, pipes, and hot water tanks would be safe. Fallout particles settle to the bottom, so the surface water of ponds or streams would be safe to use after 48 hours if not otherwise contaminated.

Do not count on a community water supply. Such supplies are likely to be contaminated during any kind of emergency in which electric power may be cut off, sewage and water lines broken, or normal operation otherwise interrupted. Until authorities have pronounced such supplies safe, keep the shut-off valve closed to preserve the supply in your household pipes.

FOOD

Provide a 2-week supply of food in or near the shelter. Choose foods that keep without refrigeration. Keep canned foods where the temperatures are between 35 and 70 degrees F. Place packaged and dried foods in metal or glass containers to prevent insect or rodent damage.

Even though the foods are for temporary, emergency use, provide for a reasonably well-balanced diet. Consider your family's preferences and that one or more members of the family may be ill. Select sizes of jars and cans that will provide just one meal. Select foods

that require little or no cooking. Enough food should be in the shelter for at least the early fallout stages, but later you could briefly leave the shelter to get other items.

Most items protected from fallout particles, and not otherwise spoiled, would be safe. Canned food and food stored in jars, waxed paper, or plastic wrappers could be eaten. Chickens and eggs would be good food sources.

Any foods that may have fallout particles on them must be handled carefully. These foods can usually be made safe by washing, brushing or peeling.

Milk from cows that had eaten fallout-contaminated food would be radioactive, but even this milk could be used if no other food were available.

SANITATION

Sanitation could become a major problem in a shelter. Trash, garbage and human wastes can not be allowed to accumulate. It must be put in newspapers, plastic bags, or other disposable containers; kept in tightly covered containers; and deposited outside the shelter area as often as necessary.

RADIO AND DOSIMETER

Two important items for any shelter are a battery radio and a radiation instrument called a dosimeter.

The radio may be your only source of outside information. As long as radio stations were broadcasting, Civil Defense authorities would give recommendations and procedures. They would send out such information as which areas had been hit, whether water supplies were safe, and who needed to remain in shelters.

Radioactivity cannot be detected by any of the five senses, so some kind of detection instrument should be included in your shelter equipment. A pocket dosimeter is a small instrument which can measure an

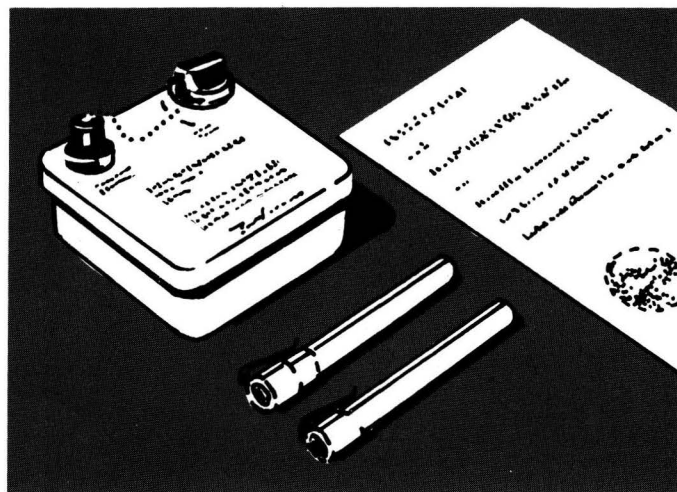

individual's total radiation dose. It would be valuable in determining how much time could be spent outside the shelter. It would be of special help if radio stations were not functioning in the area or if your radio ceased to operate. It is a relatively inexpensive instrument. Local Civil Defense authorities can help you obtain it. Follow the instructions supplied with the instrument.

VENTILATION

The shelter's ventilation system must maintain acceptable concentrations of oxygen and carbon dioxide, and keep temperatures down in hot weather.

Adequate ventilation for family shelters can be provided with vents and an open shielded doorway. The shelter should be able to draw air from about 75 square feet for each occupant. Windows outside the shelter may be opened.

Mechanical ventilation requires a 3-inch weatherproof air inlet and an intake fan. Install good-quality commercial air filters so the fresh air inlet will not draw fallout particles into the shelter. For above-ground shelters, the system must provide, for each occupant, at least 20 cubic feet of fresh air each minute during hot weather. For below-ground shelters, it must provide 3 cubic feet per minute for each occupant.

OUTLETS AND INLETS

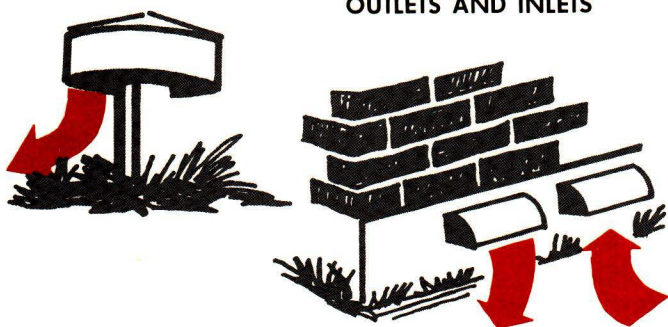

Shield inlets to keep out rain and fallout particles. Make certain that the vents are at least 12 inches above the ground so that fallout particles on the ground will not be drawn into the shelter.

A MANUAL VENTILATING SYSTEM

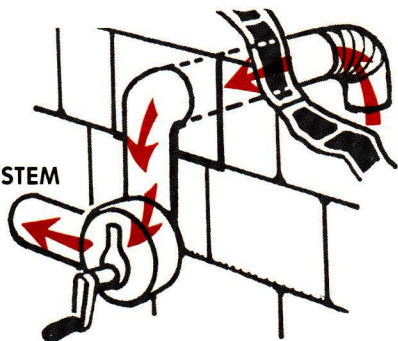

A simple hooded inlet is sufficient for hand-operated blowers.

SHIELDING — SEE PAGE 10.

HEAT

A heater may be provided for space heating, cooking, and boiling water. Install adequate venting for the heater.

SPACE

The recommended space requirements for human shelters are: (Alternative 2, page 3)

Area: 25 square feet per person if occupants will sleep on two-tier bunks; minimum total area, 50 square feet. 40 square feet per person if the occupants will sleep on cots.

Height: at least 6 feet 6 inches.

These space dimensions will provide a reasonable area for sleeping, sitting, walking, and some storage of food and supplies. More space should be provided for items such as a stove, sink or water heater which may be part of your shelter.

If fallout occurs, the first few days after an explosion must be spent within the shelter. Because radiation intensity decreases with time, you could then spend some time outside the shelter. This means that you could plan to use a less-sheltered area immediately adjacent to your shelter for storage and a larger living space. This will allow you to expand into more comfortable quarters after the first few critical days.

Consider using your shelter for some other activity. Many people are using their basement shelters for storage, photographic dark rooms, spare bedrooms, etc. These additional uses may need more space than is required for just a shelter.

The following space standard was established by the Defense Department, Office of Civil Defense, as a MINIMUM. (Alternative 1, page 3)

Area: 10 square feet per person.

Volume: 65 cubic feet per person.

LOCATION

The following drawings show some possible locations for family shelters. The numbers listed within each drawing describe the amount of shielding needed for that location.

BASEMENTS

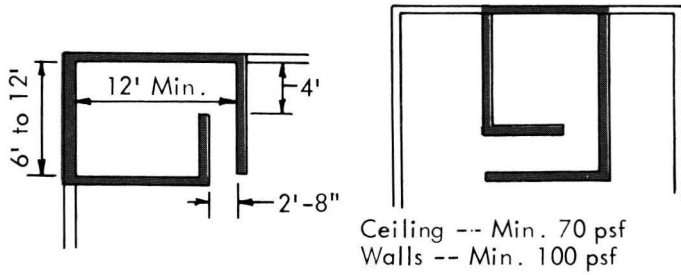

The corner shelter is usually more economical, as it uses two existing walls that already provide excellent protection.

UNDER A GARAGE

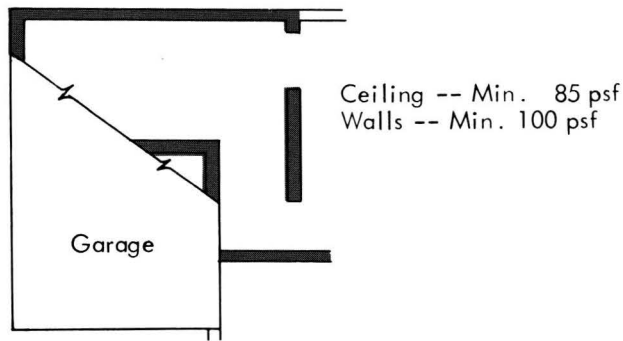

This location has the advantage of using three walls and the garage floor that have excellent protection. This design is best suited for new construction.

SEPARATE UNDERGROUND SHELTER

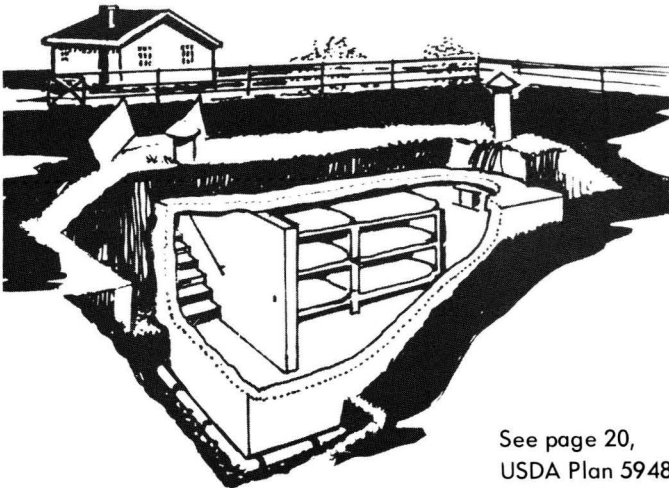

See page 20,
USDA Plan 5948

This shelter uses the dirt on all sides for maximum protection, and is usually mounded with dirt on top. A disadvantage of this shelter is that access to supplies outside the shelter may be limited. It also requires a separate ventilation system. It can be used as a cool storage for vegetables and fruit.

WITHIN A LIVESTOCK SHELTER

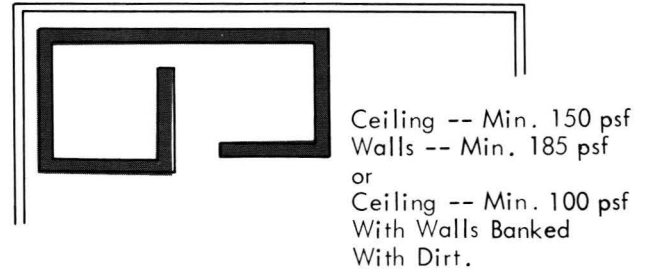

This shelter can use the shielding that is provided for the animals, and therefore requires only a little more to make it adequate for humans. It has the advantage of easy and protected access for a farmer as he cares for his animals. This shelter is an aboveground type and must have shielding for both the walls and ceiling.

WITHIN A HOUSE

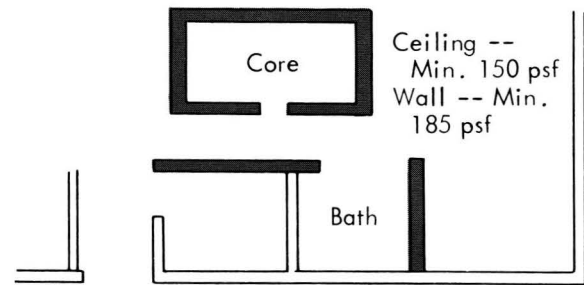

The "core" provides the most protection. The adjacent rooms provide the space to store the food, water and other items that may be needed. Both the walls and ceiling must be designed for shielding as it is an aboveground shelter.

SHIELDING REQUIREMENTS

ACCEPTABLE PROTECTION LEVELS

Livestock

Animal shelters should reduce the radiation exposure to the following percentages:

Breeding stock—4 percent (PF = 25)

Production animals—7 percent (PF = 15)

Market stock—20 percent (PF = 5)

The percentages are maximum, the PF's are minimum.

With this protection, the breeding stock would survive; production animals would be sick but most would survive; and about half of the market animals might die within 30 days.

Human

Human shelters should reduce the radiation exposure to a maximum of 2 1/2 percent (PF = 40). With this protection, the radiation dose would probably be less than 150 roentgens in the first week (see table, page 1).

IMPROVING SHIELDING

The table below lists the weight of materials required to reduce radiation from fallout particles to the acceptable levels. This table can help you increase the protection of your own selected shelters. There are many factors that affect shelter designs—this table is only a guide. See CONSTRUCTING SHELTERS, pages 14 to 20, for details on installing shielding.

Procedure

Step 1. Select the case which most nearly fits your situation. The shaded area shows where you must use heavy materials. In the first three cases, heavy materials must be added only to the roof or ceiling; in Case IV, both the top and sides must be of heavy materials.

Step 2. Select the protection level needed (percentage of outdoor radiation in shelter). From the table below, select the weight of the materials that must be used in construction.

Step 3. Choose the materials you will use in constructing the shelter, and determine the thickness needed.

Materials

Materials	Pounds per sq. ft. for each 1" of thickness
Concrete	121/2
Brick	10
Sand and soil	81/2
Standard concrete blocks	7
Water	51/4
Small grain	4
Wood	3
Baled hay	1
Loose hay	1/3

Step 4. Construct the shelter. See pages 8 and 14 to 20 for possible locations and arrangements of human shelters, and for construction details and information for both human and livestock shelters.

Example

A shed is to be converted to a fallout shelter for cattle. The livestock are to be protected to the 7 percent level.

It is decided to use a dirt mound for the walls, and to install a wood joist ceiling and fill the space between the joists with sand.

The shelter is similar to Case III in the table.

The dirt mounds will give sufficient protection for the walls, and 9 inches of sand in the ceiling will give the needed weight of 75 psf.

ENTS

WEIGHT OF SHIELDING REQUIRED for the Following Types of Shelters

psf = Pounds per square foot

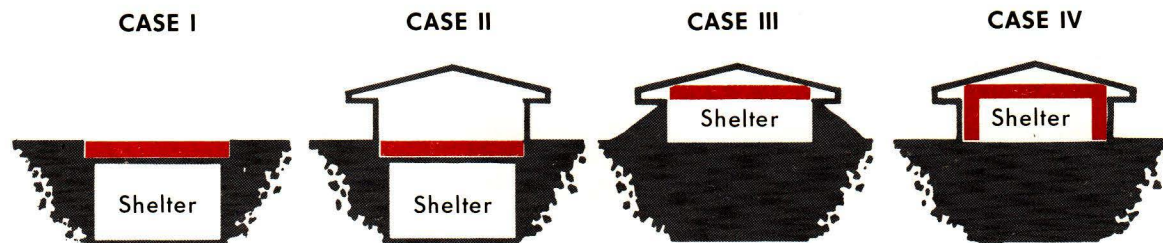

Required Radiation Level

Weight needed in ceiling

Weight needed in floor

Weight needed in ceiling

Weight needed in roof in walls

2 1/2 percent
(Family)

85 psf

75 psf

125 psf

150 psf 185psf
or 100psf 250psf

4 percent
(Breeding stock)

75 psf

70 psf

125 psf

150 psf 150psf
or 75 psf 215psf

7 percent
(Production stock)

50 psf

50 psf

75 psf

150 psf 120psf
or 75 psf 130psf

20 percent
(Market stock)

10 psf

5 psf

25 psf

150 psf 60psf
or 75 psf 65psf

INADEQUATE SHELTERS

ANALYSIS OF TYPICAL BUILDINGS

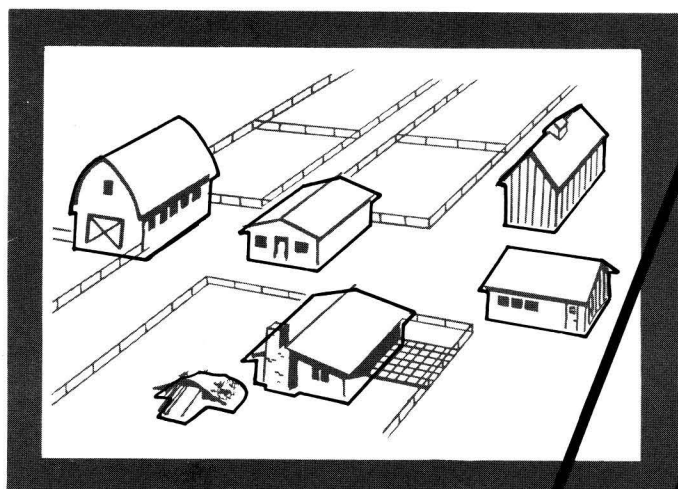

STANCHION BARN

Adequate feed and water in or near the barn. No emergency power.

Insufficient shielding material. The inside radiation level of a wood-frame barn would be about 60 percent. The same barn with 10 feet of hay in the mow would have 50 percent of outside radiation. Masonry walls and 10 feet of hay would reduce the level to 22 percent.

SWINE OR POULTRY BUILDING

Adequate feed and water in or near the building. No emergency power.

Insufficient shielding material. The radiation level within a wood frame plywood-lined building would be about 60 percent of outside radiation. The level within the same building with 8-inch masonry walls would be about 22 percent.

EAR CORN CRIB

Corn for feed, no water in or close by, and no emergency power.

Insufficient shielding materials. The radiation level in the alley would be:

Radiation Level	Sidecribs	Overhead bins
80%	Empty	Empty
65%	Empty	Full
27%	Full	Empty
22%	Full	Full

GARAGE OR MACHINE SHED— metal siding, no lining

No feed, water, or emergency power. Animal restraints are usually missing.

Insufficient shielding materials. The inside radiation level would be about 65 percent of the outside level.

HOUSE

Food and water easily accessible. An emergency power supply, possibly.

Insufficient shielding materials; some shielding in a basement. A wood-frame house would have radiation levels of 50 percent on the ground floor; 10 percent in the basement. A wood-frame house with a brick siding would have levels of 30 percent on the first floor, and 8 percent in the basement.

TORNADO SHELTER—

Accessibility to food and water is limited to what may be inside the shelter. No emergency power, probably.

Lacking some shielding. A shelter submerged 5 feet into the ground and with a 6-inch dirt cover would have an inside radiation level of 8 percent.

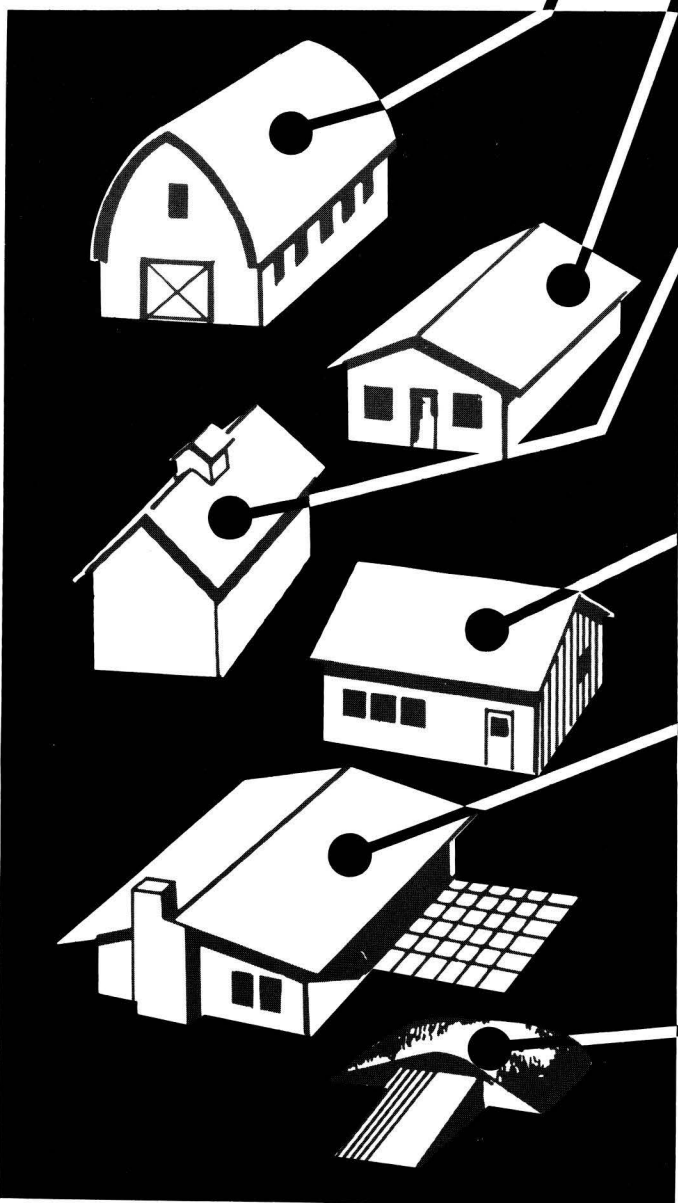

ADEQUATE SHELTERS

TYPICAL BUILDINGS WITH SHIELDING IMPROVED

Use ceiling designs, page 15, or consult an engineer before adding heavy shielding materials to ceilings.

RECOMMENDED MAXIMUM RADIATION LEVEL WITHIN SHELTERS

- Human shelters—2 1/2 percent
- Livestock shelters—
 - Breeding stock—4 percent
 - Production stock—7 percent
 - Market stock—20 percent

BARN LIVESTOCK SHELTER

Provide emergency power, feed and water.

SHIELDING		INSIDE RADIATION
WALLS	CEILING	
Earth bank	16" sand	1%
Earth bank	8" sand	4%
Earth bank	0" sand	9%
Earth bank	16" sand	8%
3 sides, 1 wall exposed		

HOG OR POULTRY HOUSE

Place a 3' high, 12" concrete wall around the building. Add 4" sand or equivalent to the ceiling. Provide feed and water.

EMERGENCY LIVESTOCK SHELTER

(When cribs and bins are full)

Stack baled hay inside doors 4' high 10' thick. Provide feed and water.

BANK BARN (1" roof sheathing and 1" mow floor)

Shield the endwalls with a dirt mound. Provide feed, water, and emergency power.

EXPOSED WALL	INSIDE RADIATION
1" Wood	18%
12" Block	12%
8" Concrete	11%
12" Concrete	8%

HOUSE

Provide for food and water. Add sufficient shielding to reduce radiation level to 2 1/2%.

TORNADO SHELTER

Twelve-inch dirt cover; shield entrance. Provide food, water and other supplies.

EMERGENCY SHELTER (Trench Silo or Concrete Bunker)

Cover trench with plastic before fallout starts. Remove plastic as soon as possible after fallout is down. Provide water.

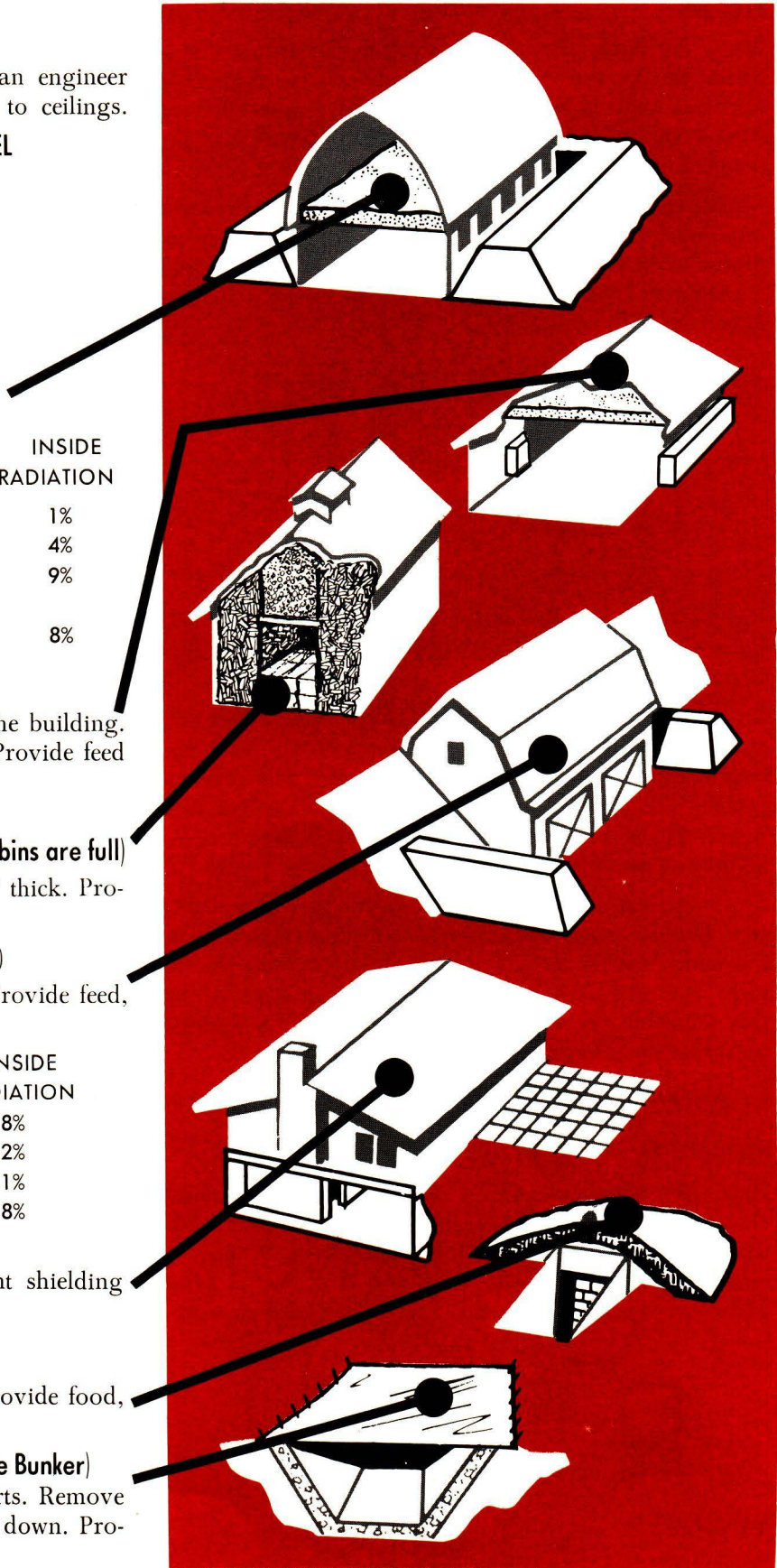

CONSTRUCTING SHELTERS

FLOORS

Slope the floor of a shelter toward the entrance or a drain in the shelter. The floor should be made of a material that is easily cleaned, easily installed, and strong enough to hold the weight of the wall and the people and equipment that will be in it.

Most concrete floors in existing basements and livestock buildings will support the weight of the shielding required in the ceiling and wall of a shelter. When building a shelter in a new building, it is best to install a footing under the walls or supports.

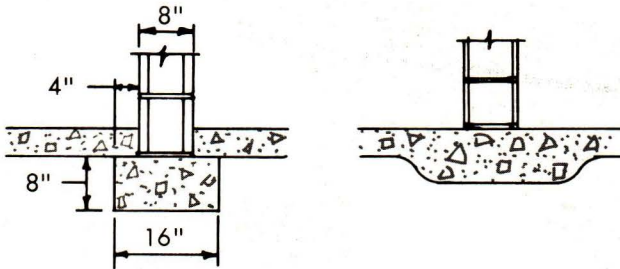

Provide drainage for underground water. Many new houses have drain tile installed around the house that handles this water.

For houses that do not have this tile, a drainage line can be installed under the basement floor. This will require cutting a trench, installing tile, and then replacing the concrete. Lay 4-inch field tile about 1/8 inch apart. Put a strip of tar paper over each joint to keep solids out, and then cover with coarse gravel.

Drainage lines must have an outlet. A sump works well, but may require standby electrical power to operate the pump during an emergency. In some areas the tile may discharge into a storm sewer, but in other areas, this is prohibited. Check local codes. Consult a plumber on sump installation.



ENTRANCES

Entrances must permit easy access, yet protect against radiation. Baffle walls are required to shield entrances. They are effective because radiation travels only in straight lines. The baffle wall should have the same radiation resistance as the rest of the shelter walls.



WINDOWS

Shield windows that will be exposed to fallout. The drawings below show how this can be done.

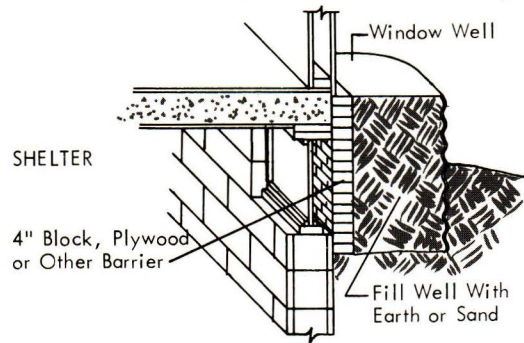
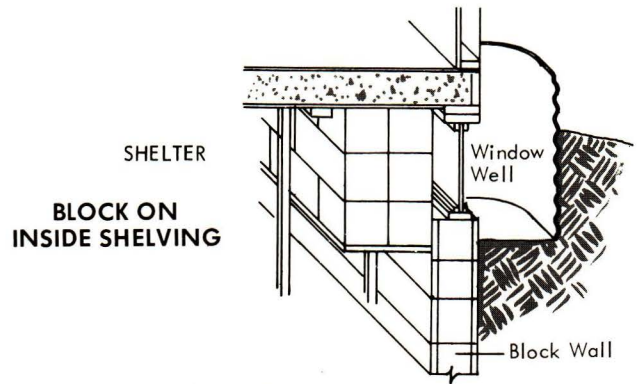

When planning the shelter as part of a new house or building, avoid placing exposed windows in the shelter area. A desirable construction for a shelter area in a new house is shown in the drawing below.

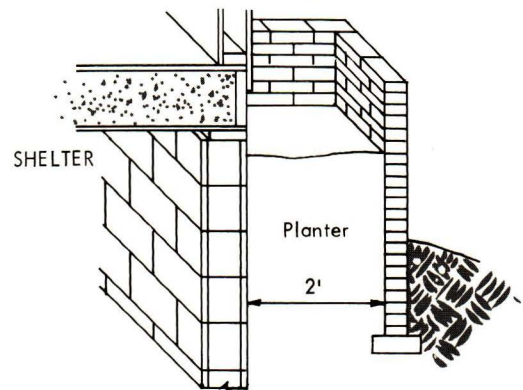

WALLS

Construct shelter walls with 8-inch sandfilled concrete block, or 8-inch solid concrete. Below-grade exterior walls do not need masonry cores filled. These materials will provide adequate shielding. Consult a local contractor if you desire a poured concrete wall.

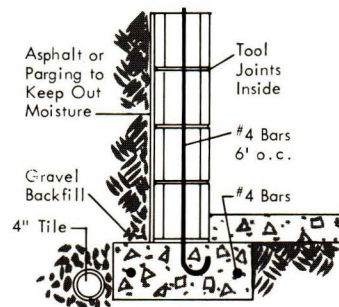

EXTERIOR WALL

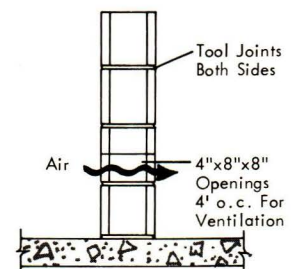

PARTITION

EARTH BANK WALL

An earth bank 6 feet high will shield most animals or humans within a building. The bank should be sodded and sloped for mowing. The ventilation doors may be opened with little effect on shielding.

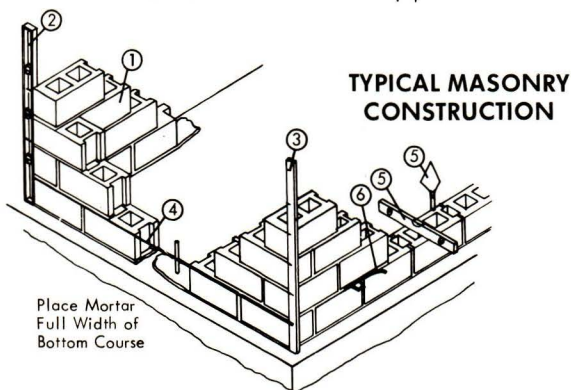
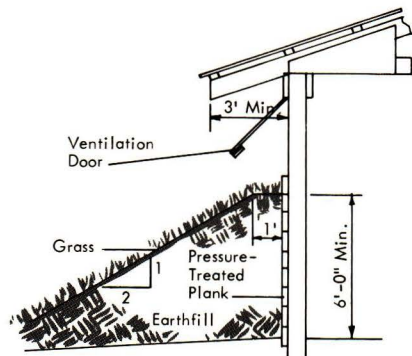

TYPICAL MASONRY CONSTRUCTION

Place Mortar Full Width of Bottom Course

1. Corners are built first, 4 or 5 courses high.
2. After each corner course is laid, check with level for alignment and plumbness.
3. 1" x 2" board with markings 8 in. apart for accurately finding top of each course.
4. Mason's line from corner to corner to insure horizontal accuracy.
5. Block are brought to proper grade and made plumb by tapping with a trowel handle.
6. Round "O" or "V" shaped tool. Run along joints after mortar has somewhat stiffened. This improves watertightness.

CEILINGS

If concrete is to be used as the ceiling of a basement shelter, it should be at least 6 inches thick. The concrete ceiling over a shelter that is under a garage must be at least 8 inches thick.

These concrete slabs can be covered with sand, dirt or other heavy shielding material.

However, when a concrete roof or ceiling will be covered with some other heavy material, it will require more reinforcing bars to support the added weight. The drawing and table below show the reinforcing needed to support sand over 6 inches of concrete.

Consult an engineer for the design of other ceiling systems.

REINFORCED CONCRETE CEILINGS

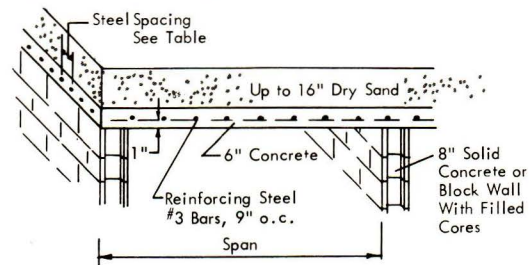

REINFORCING STEEL REQUIRED IN A 6" CONCRETE CEILING

Span	Up to 4" of sand over the concrete	Up to 16" of sand over the concrete
8'	#3 bars 8" o.c.	#3 bars 6" o.c.
10'	#3 bars 7" o.c.	#4 bars 6" o.c.
12'	#3 bars 5" o.c.	#5 bars 6" o.c.

Place the specified bars parallel to the span.

Place #3 bars, 9" o.c. perpendicular to the span for all 3 spans.

16" sand plus 6" concrete weighs 210 psf.

12" sand plus 6" concrete weighs 175 psf.

8" sand plus 6" concrete weighs 145 psf.

4" sand plus 6" concrete weighs 110 psf.

The total weight must at least equal the required weight found in the table on page 11.

WOOD FRAME CEILINGS

The drawing and table below describe how to use existing floor joists and sand as the shielding material.

Locate your interior shelter wall to reduce present joist span to the Maximum Span indicated in the table.

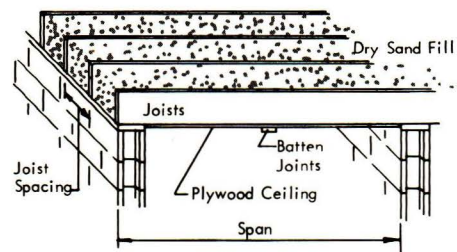

Maximum span	Joist size	Joist spacing	Max. depth of sand	Plywood size
7ft.	2 x 8	24"	8"	1/2
8ft.	2 x 8	16"	8"	3/8
	2 x 10	20"	10"	3/8
12ft.	2 x 12	12"	24"	3/8
	2 x 12	24"	12"	1/2

The depth of the sand may be limited by the fact that there is a floor above the joists. This is true for basement shelters.

Nail plywood to joists with 8d hardened threaded nails. Space up to 6 inches apart. Use exterior plywood.

EXAMPLE-BASEMENT SHELTER

A family of four elects to build a shelter in their basement. They decide they will sleep in bunks, so the space required is 100 square feet. (Four people times 25 square feet per person).

They find on page 11 that their type of shelter is similar to Case II, and they need about 75 pounds of material in each square foot of the ceiling.

The joists in the house are 2" x 10", 16 inches on center, so a span of up to 8 feet can be used. They decide to fill the space between the joists with sand, so they will get the protection of about 10 inches of sand. This is equal to a material weight of about 85 pounds per square foot. (10 inches weighs about 85 psf)

They decide to provide extra space so that more supplies can be stored within the shelter. They select an 8-foot by 14-foot shelter, which provides 112 square feet. They build the shelter using the details on pages 14 and 15 and the suggestions of a local builder.

The drawings on this page show some of the details that can be used for making such a basement shelter.

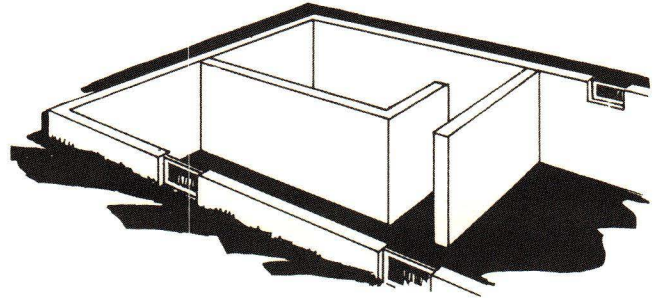

NOTE

The radiation level of this particular shelter is 2 percent. The same protection would be obtained if 8 inches of concrete had been substituted for the 10 inches of sand.

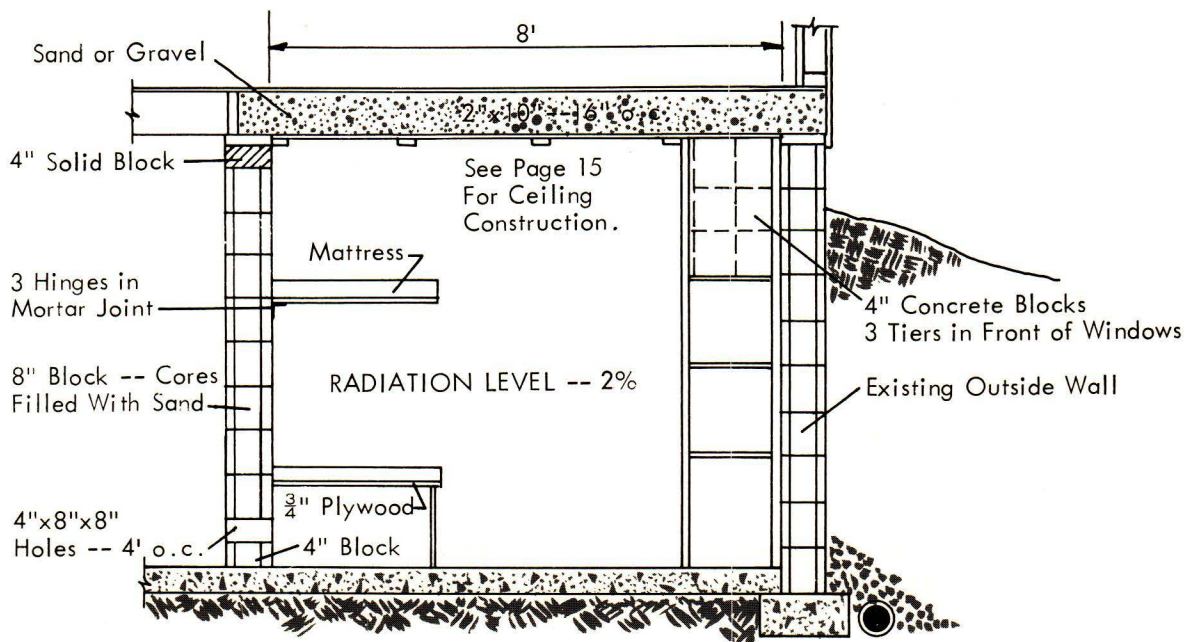
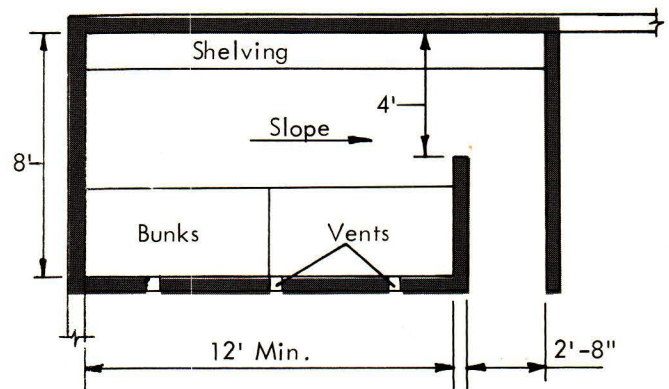

EXAMPLE-SHELTER UNDER GARAGE FLOOR

The drawings on this page show typical construction details of a shelter under a garage floor. The exact size is determined by the number of people that will use the shelter. Consider this type of shelter when building a new house or garage. It is not very practical for an existing house or garage.

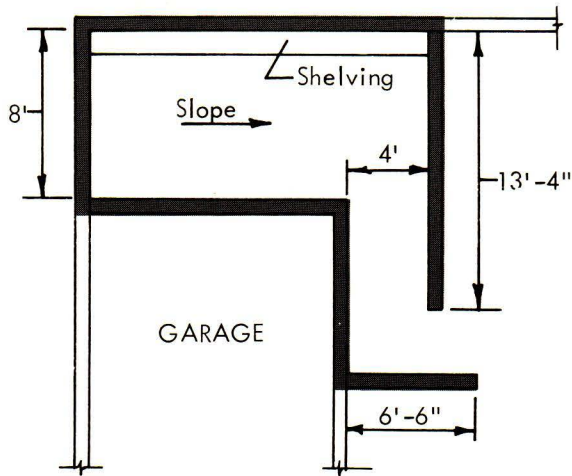

FLOOR PLAN

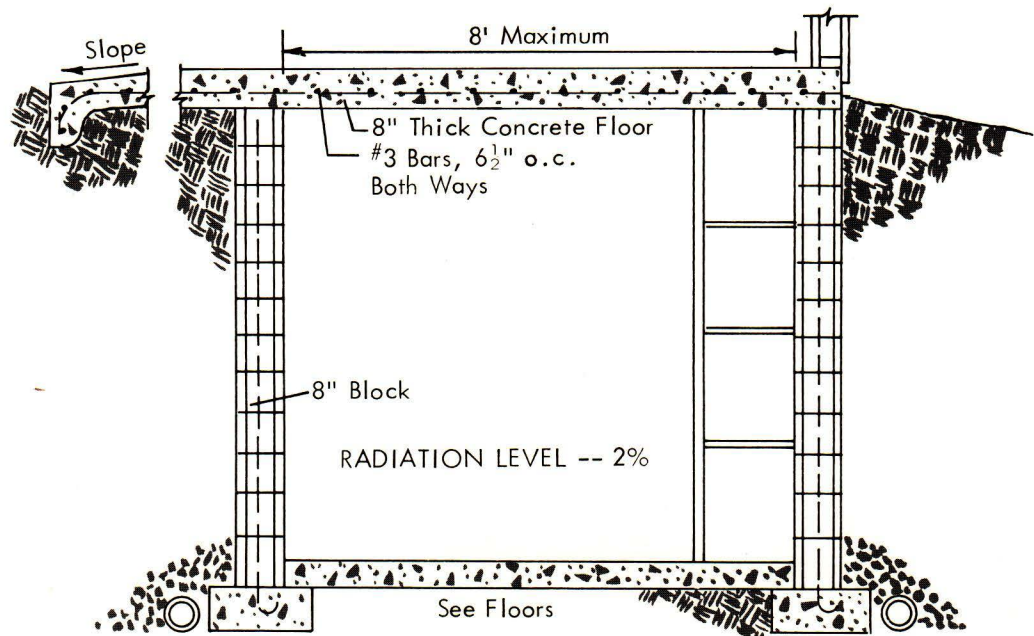
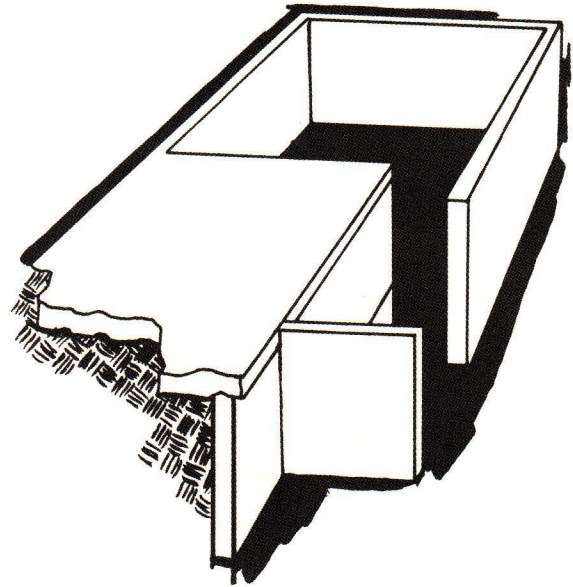

SECTION

EXAMPLE-COMBINATION HUMAN AND ANIMAL SHELTER

These two pages show construction details for a family shelter within a livestock shelter. The emergency electric generator serves both family and livestock needs.

The livestock portion of the shelter will have the radiation level reduced to about 10 percent of that outside the building. The back portion of the livestock area will offer a little more protection; so some means of restraining the most important animals in this area should be installed.

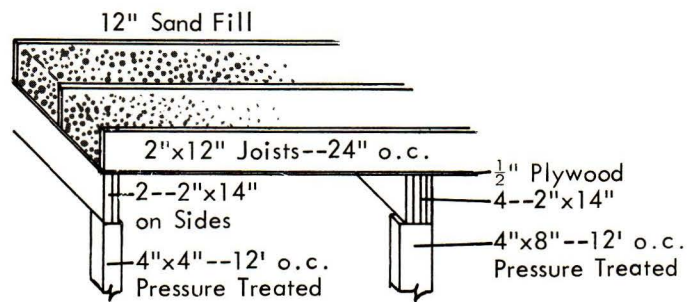
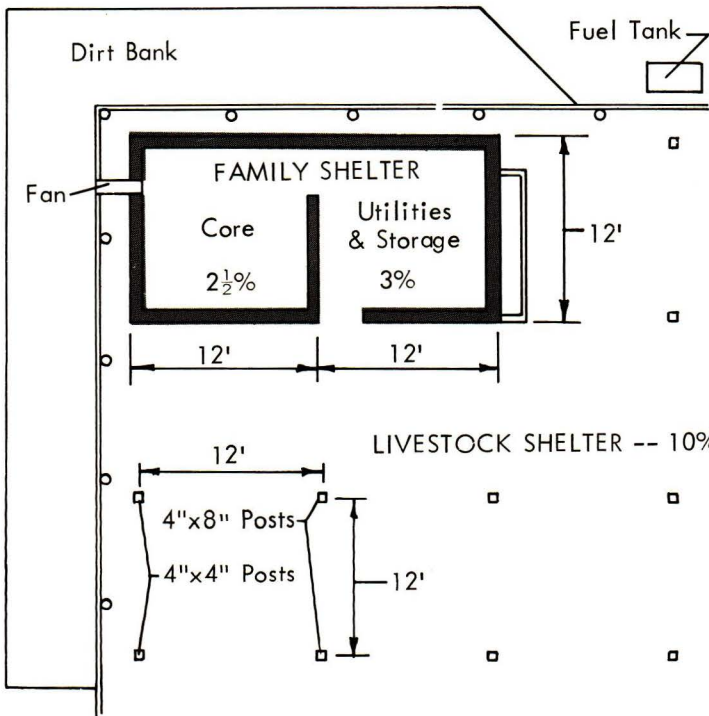
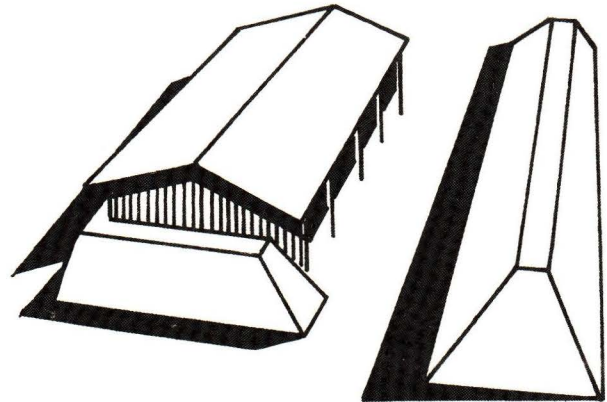

CEILING CONSTRUCTION
Livestock Shelter

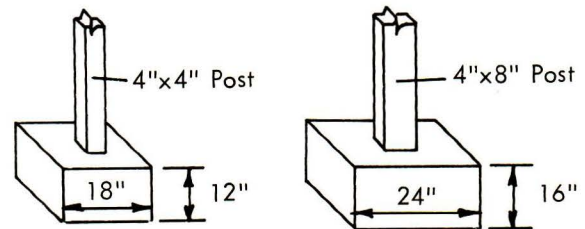

FOOTING DETAILS

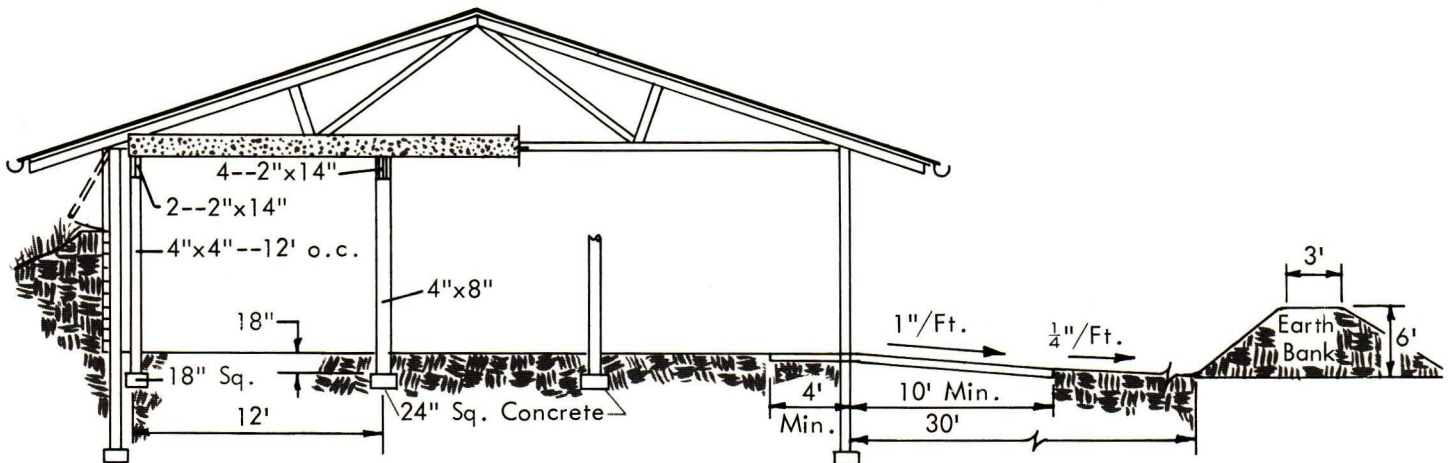

SECTION OF LIVESTOCK SHELTER

The family shelter is adequate for a family of 5 or 6. The radiation level in the "core" shelter would be about 2 1/2 percent of that outside the building. The utility area radiation level would be about 3 percent.

The family shelter should be placed close to the back and one side of the building. This location takes advantage of the shielding given by the dirt mounds.

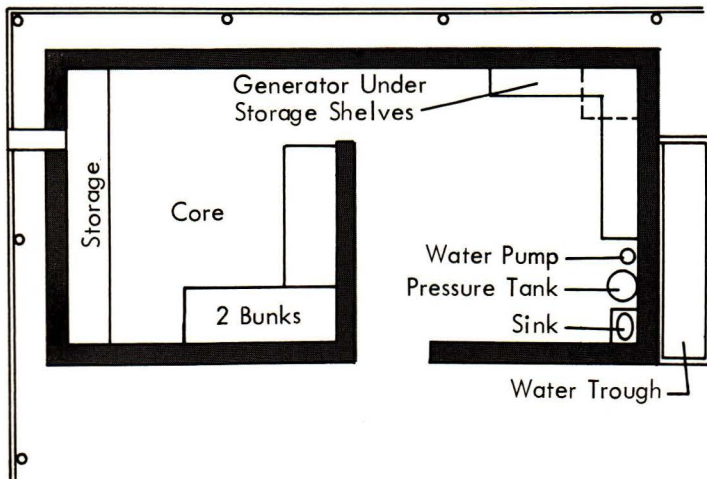
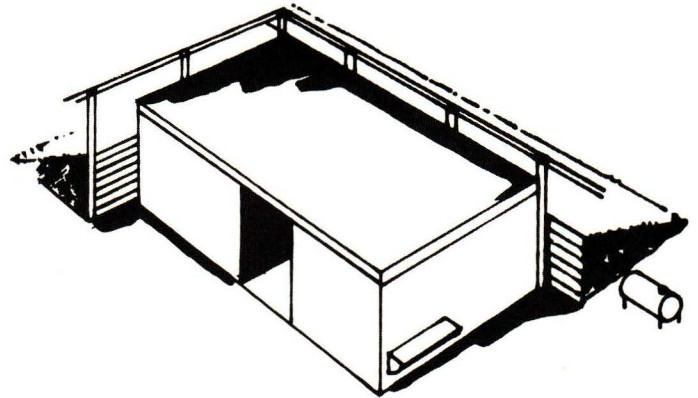

FAMILY SHELTER

This type of shelter could be built into any protected livestock area. As an example, it would work well in the protected barn illustrated on page 13.

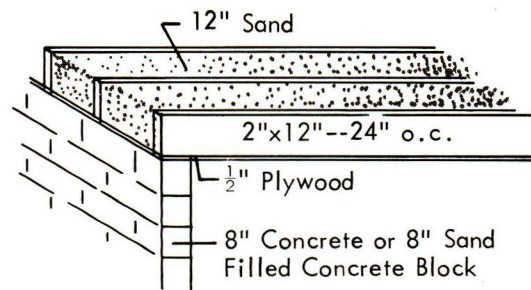

CEILING CONSTRUCTION
Family Shelter

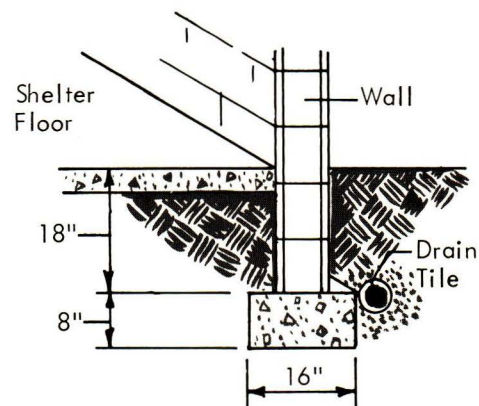
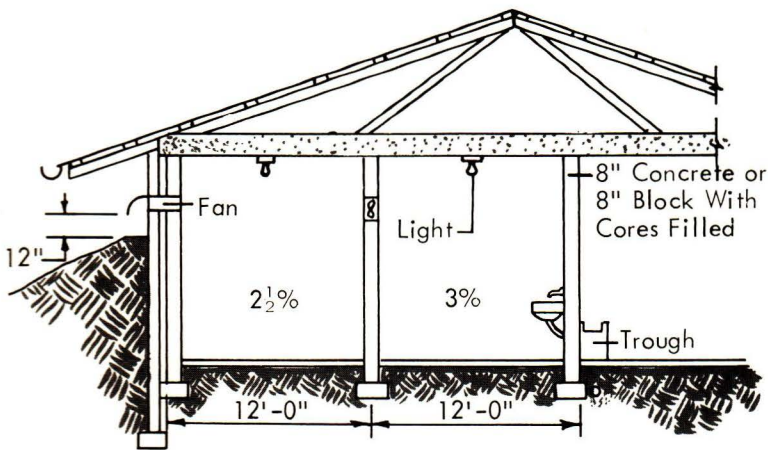

FOUNDATION DETAIL
Family Shelter

COMPLETE PLANS FOR FALLOUT SHELTERS:

To obtain USDA plans: Contact your county's Co-operative Extension Agent, or write to the Extension Agricultural Engineer at your state's College of Agriculture.

HUMAN SHELTERS

FALLOUT SHELTER AND STORAGE — USDA 7166

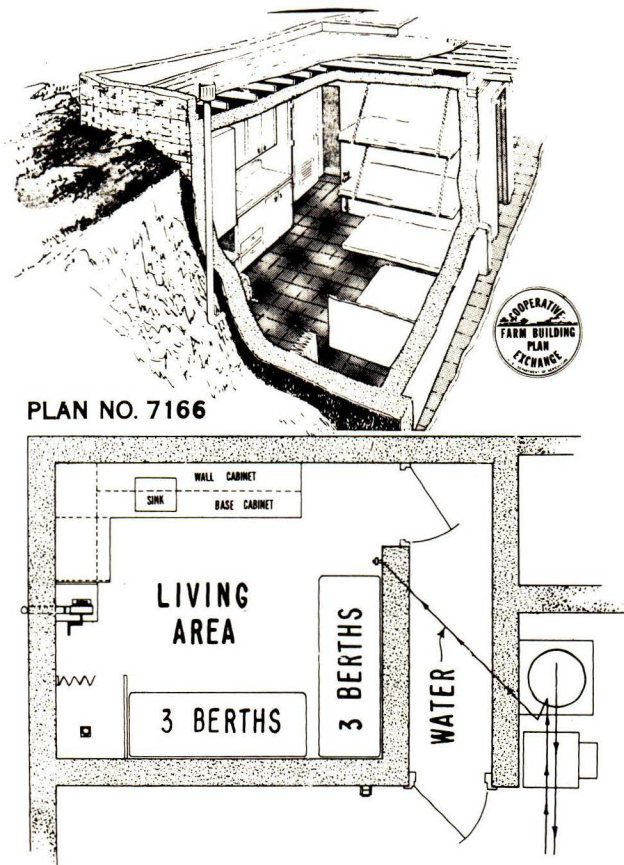

USDA Plan 5934, an underground shelter and storage. The shelter accommodates five people at 20 sq. ft. per person.

USDA Plan 5948, an underground storage, storm and fallout shelter for six people at 24 sq. ft. per person.

USDA Plan 5951, a fallout shelter for four people at 25 sq. ft. per person; it is built in an underground farm potato storage.

USDA Plan 5957, an underground blast and fallout shelter for four people at 28 sq. ft. per person.

USDA Plan 7166, an underground fallout shelter designed to be built at the same time a new house is built. The shelter will accommodate six people at 20 sq. ft. per person.

LIVESTOCK SHELTERS

FALLOUT SHELTER FOR 40-COW DAIRY AND 6-MEMBER FAMILY—USDA 5937

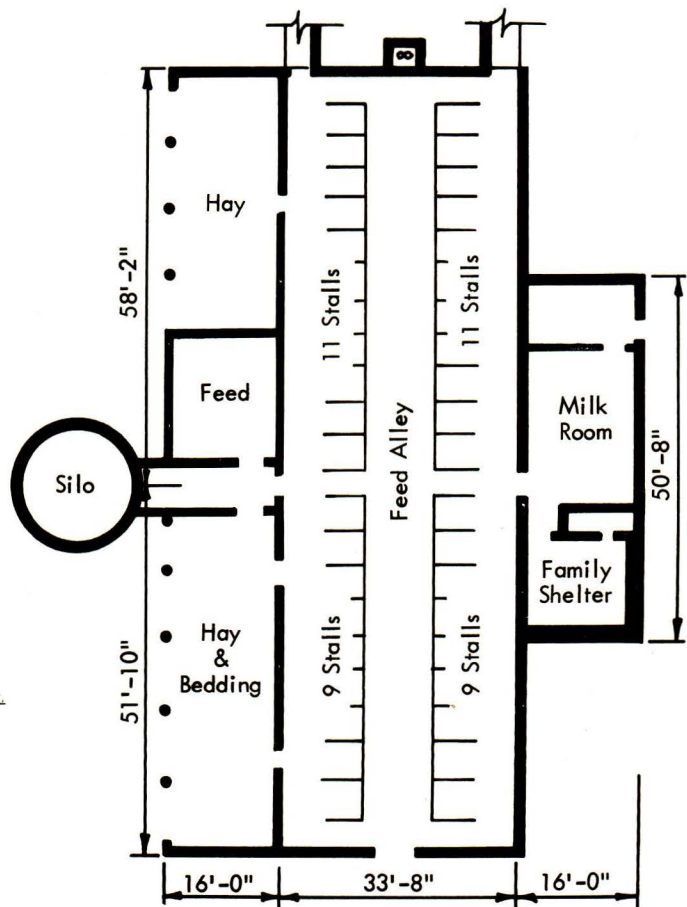

USDA Plan 5937, Floor plan shown.

USDA Plan 5938, Similar plan with silo at end of feed alley.

USDA Plan 5953, stall barn and fallout shelter for 50 cows; milkroom and family shelter at one end.

USDA Plan 5954, 45' x 91' pole shed with 60 stalls, calf pens, and hay storage. Slotted alley floors over manure flumes. Wash-down roof decontamination system.

USDA Plan 5955, Same as 5954 except manure is removed by scraping solid alley floors.

This book was developed by a special committee of the Midwest Plan Service. This was in response to a request and grant from the Federal Extension Service of the U. S. Department of Agriculture. Committee members represented the Agricultural Engineering Departments and Civil Defense programs of their respective universities.

Members

S. A. Witzel, Chairman, Wisconsin
O.E. Cross, Nebraska
D. W. Johnson, North Dakota
R. O. Gilden, FES-USDA
J. H. Pedersen, ex officio, Midwest Plan Service

Consultants

F. G. Bergsrud, Kansas
H. J. Hirning, Iowa
F. A. Painter, Illinois
C. E. Richardson, Indiana
V. L. Stine, Michigan
C. F. Halsey, Minnesota
C. E. Stevens, Missouri
R. A. Miller, Ohio
C. N. Hinkle, South Dakota
W. C. Dries, Wisconsin
D. V. Jensen, Wisconsin

The Midwest Plan Service is an official activity of 13 Land-Grant Universities and the U. S. Department of Agriculture. The following are cooperating members:

University of Alaska College, Alaska 99645	University of Missouri Columbia, Missouri 65201
University of Illinois Urbana, Illinois 61801	University of Nebraska Lincoln, Nebraska 68503
Purdue University Lafayette, Indiana 47907	North Dakota State University Fargo, North Dakota 58103
Iowa State University Ames, Iowa 50010	Ohio State University Columbus, Ohio 43210
Kansas State University Manhattan, Kansas 66504	South Dakota State University Brookings, South Dakota 57007
Michigan State University East Lansing, Michigan 48823	University of Wisconsin Madison, Wisconsin 53706
University of Minnesota St. Paul, Minnesota 55101	Midwest Plan Service Iowa State University Ames, Iowa 50010

For additional copies of this book, write:

EXTENSION AGRICULTURAL ENGINEER
at any of the above institutions.

SHOULD A NUCLEAR EMERGENCY OCCUR

The two public warning signals are:

A 3- to 5-minute **STEADY TONE**, meaning, turn on your radio for directions from local authorities.

A 3-minute **WARBLING TONE** or **SHORT BLASTS**, meaning, take cover immediately.

Move family to shelter, then move livestock.

Check lists of needed supplies; move last-minute items to shelter.

Start emergency generator.

Tune battery radio to civil defense broadcasts to obtain information on community and national situation.

HOW LONG IN YOUR SHELTER.

If no communication is available, stay in your shelter as long as possible. If you must leave to obtain additional supplies for family or livestock, use the following schedule.

Live in shelter at least 2 weeks.

After 2 days, adults may spend up to 1 hour each day outside the family shelter.

After a week, leave the shelter for no more than 3 hours per day.

Use the dosimeter to check accumulated radiation dose, page 1. Change clothing after re-entering family shelter. Hang soiled clothing outside the shelter. Shake dust from clothing before using again.

EMERGENCY HOUSEKEEPING.

List of equipment and supplies	p.	6
What is safe food and water?	p.	7
Suggested sanitation procedures	p.	7
Using the emergency generator	p.	5
Caring for livestock	p.	4

IF YOU COULD NOT GET TO YOUR SHELTER.

If the warning should sound when you were too far away to get to your family shelter, you could go to the nearest designated public shelter. Buildings which provide adequate shelter have been identified with this yellow and black sign.



